

User Manual

MPNE1001 series

Modbus RTU interface



Via Fermi 57/59, 10091 Alpignano (TO), Italy

 [+39 011 9664616](tel:+390119664616) - srlmect@mect.it

C.F. e P.I. 04056380019

mect.it

ME7087_17
04/26

INDEX

1	Introduction	5
1.1	Staff qualification	5
1.2	Symbols.....	5
1.3	Nomenclature.....	5
1.4	Security	6
2	Hardware features.....	7
2.1	System description.....	7
2.2	Features.....	7
2.2.1	BASE inputs / outputs electric features	8
2.2.2	EXPANSION digital inputs electric features – CODE 01.....	9
2.2.3	EXPANSION digital outputs electric features – CODE 02.....	9
2.2.4	EXPANSION analog inputs / outputs electric features – CODE 05	9
2.2.5	EXPANSION digital outputs electric features – CODE 06 (PRELIMINARY).....	10
2.3	Electromagnetic compatibility.....	10
3	Product architecture.....	10
3.1	Models.....	12
3.2	Installation	13
3.2.1	Distances	13
3.3	MPNE1001 Wiring	13
3.3.1	Isolation	13
3.3.2	System power supply	14
3.3.3	Digital outputs power supply	15
3.3.4	Fuses.....	15
3.3.5	Grounding.....	16
3.3.6	Cable screen	16
3.4	I/O Connection.....	16
3.4.1	Base connection.....	16
3.4.1.1	Base connection - encoder	17
3.4.2	Base + expansion digital inputs connection.....	18

3.4.3	Digital inputs connection	18
3.4.4	Base + expansion digital outputs connection.....	19
3.4.5	Digital outputs connection	19
3.4.6	Base + expansion analogue inputs / outputs connection.....	20
3.4.7	Analog inputs / output connection	20
3.4.8	3A current input connection (PRELIMINARY).....	21
4	Modbus.....	22
4.1	Modbus parameters configurations.....	22
4.1.1	Address (ID module).....	22
4.1.2	Baud Rate settings	23
4.1.3	Parity and stop bit configuration	23
4.1.4	Factory configuration	25
4.2	ModBus connection	26
4.2.1	Installation example TPAC1007 / TP1043	26
4.2.2	Installation example TPAC1008 / TP1070	27
4.2.3	Terminating resistance	27
4.3	Watchdog	27
5	Memory map ModBus RTU registers.....	28
5.1	Special functions.....	35
5.1.1	Functions definition.....	36
5.1.2	Variables.....	37
5.1.3	Management of IOs	40
5.2	Module 06 Functions (PRELIMINARY)	44
5.2.1	Monostable outputs	44
5.2.2	Using lines as monostable	45
5.2.3	Using lines as PWM.....	46
6	Status led	47
6.1	Led On	47
6.2	Led RUN.....	47
6.3	Led LINK.....	47
6.4	Digital I/O Led.....	47

1 Introduction

To ensure a quick installation of the device please follow carefully the information given in this manual.

1.1 Staff qualification

Products described here are to be used exclusively by personnel with experience in programming PLCs, or technician specialized in the use of electrical device for automation. MECT S.r.l declines any responsibility for malfunctions or damages caused by improper use of MECT devices, due to the non-compliance with information in this manual. In MECT S.r.l there is an help desk service.

1.2 Symbols

**Danger**

Follow these advices to avoid people injury.

**Warning**

Follow these advices to protect the device.

**Caution**

Follow this advices to have a more effective performance.

**ESD (Electrostatic discharge)**

Danger: possibility of components damage due to electrostatic discharge.

**Note**

Steps to follow for a correct installation

**Additional information**

1.3 Nomenclature

Modbus RTU interface: MPNE1001

Operator Panel: TP1070

System: MPNE1001 + TP1070

1.4 Security

**Attention**

Switch off devices before connecting them .

**Attention**

MPNE1001 must be mounted inside cabinet or electrical switchboards whose access must be performed by qualified personnel.

**ESD** (Electrostatic discharge)

Modules have electronic components that can be damaged by electrostatic discharge. Be sure to be connected to ground when handle the devices .

The instrument has not power switch and not internal fuse, but it powers on immediately after the correct supply voltage has been supplied (check the value of the supply voltage indicated on the instrument label under “Supply”). Provide a power supply line as direct as possible and separate from the line that supplies the power elements.

For safety regulations, it is necessary to provide a two-phase switch-disconnector with fuse located near the instrument and easily replaceable.

Avoid the presence of power elements (contactors, motors, drives, etc.), excessive humidity, heat sources and corrosive gases in the same panel.

Instruments must be powered by safety transformers or by SELV-type power supplies.

2 Hardware features

2.1 System description

The MPNE1001 is a RTU Modbus bus coupler device, the RS485 ModBus / RTU slave interface allows the MPNE1001 to communicate with an operator panel or a PLC. MPNE1001 is a modular device consisting of a base plus one or two expansions to obtain different configurations of inputs and outputs. The available expansions are:

- 8 digital inputs
- 8 digital outputs
- 2 analog inputs and 1 analog output
- 8 digital outputs and 1 current input of SHUNT (PRELIMINARY)

The expansions are modular to each other in any combination.

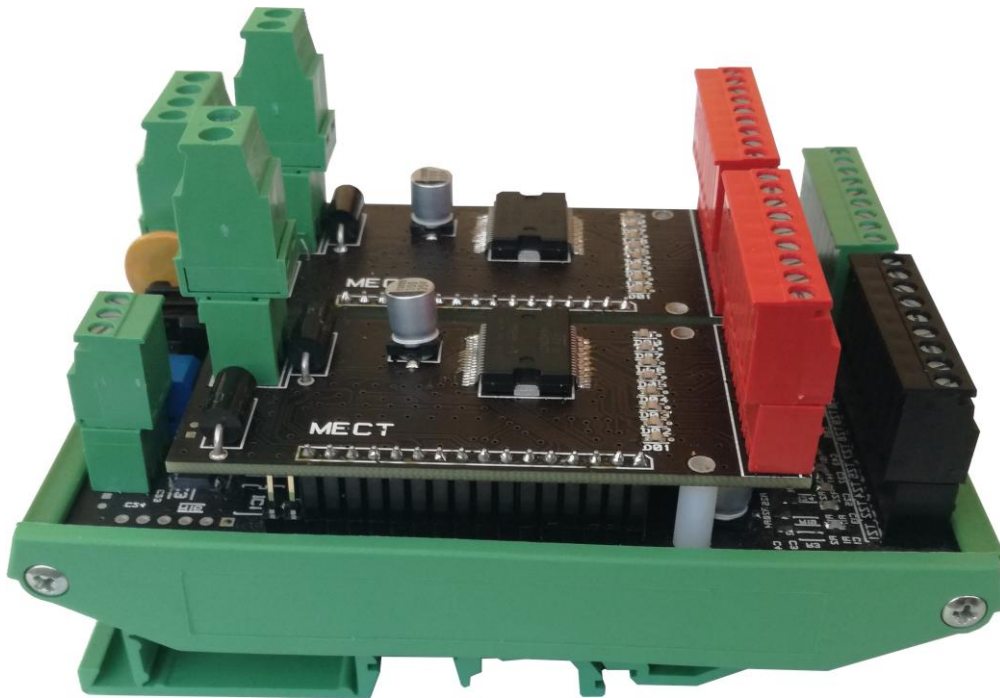

2.2 Features

Mechanics	
Power supply	24Vdc +/-15% 3W
Base dimensions W x H x L	80 x 60 x120mm (4 DIN modules)
Base + expansions dimensions W x H x L	80 x 80 x 120mm (4 DIN modules)
Installation	DIN 35
Climatic conditions	

Operative temperature	0 °C ÷ 55 °C
Storage temperature	-20 °C ÷ +85 °C
Relative humidity	From 5 % to 95 % no condensation
Electric isolation	
Air clearance	According to IEC 60664-1
Pollution according to IEC 61131-2	2
Digital inputs	
Digital inputs	0V - 24Vdc +/- 15%
Max current for each digital output – CODE 02	200mAdc@24 Vdc
Max current for each digital output – CODE 06	500mAdc@24 Vdc
Max number of analog inputs	4 (MPNE1001-05-05 model)
Type of selectable analog inputs	PT100, TCJ, TCK, TCT, TCB, TCR, TCS, V, mA
Dissipated power without loads	0.5 W

2.2.1 BASE inputs / outputs electric features

		Line type	Update	Note
Configurable digital I/O	8	PNP	Modbus cycle time	Max 200mA for each output. max 2A totally. Output 8 is a high frequency output (max 65kHz) and configurable as PTO
Digital inputs	8	PNP	Modbus cycle time	
Encoder input	1	PNP	max frequency 40kHz	2 of the 8 inputs (In9 and In10) are used as inputs for encoder

Unidirectional conuter inputs	3	PNP	max frequency 500Hz	IN14, IN15, IN16
--------------------------------------	---	-----	---------------------	------------------

2.2.2 EXPANSION digital inputs electric features – CODE 01

Digital inputs	8	Line type	Resolution	Note
		PNP	Modbus cycle time	

2.2.3 EXPANSION digital outputs electric features – CODE 02

Digital outputs	8	Line type	Resolution	Note
		PNP	Modbus cycle time	Max 200mA for each output. max 2A totally.

2.2.4 EXPANSION analog inputs / outputs electric features – CODE 05

		Input type	Resolution	Note
Analog inputs	2	0÷20 mA (0÷20000)	0.005mA	Input impedance 9Ω
		0÷10V (0÷10000)	0.003V	Input impedance 1M Ω
		Thermocouple: J (0°C – 600°C) T (0°C – 400°C) K (0°C – 800°C) B (100°C – 1800°C) R (0°C – 1500°C) S (0°C – 1700°C)	1°C	Cold junction compensation
		PT100 E: -40°C +800°C	1°C	Degree resolution
		PT100 r: -40.0°C +200.0°C	0.1°C	Tenth of degree resolution
		Analog outputs	1	0 (4)÷20 mA (0÷2000)
0÷10V (0÷1000)	12bit			Min impedance 1kΩ

2.2.5 EXPANSION digital outputs electric features – CODE 06 (PRELIMINARY)

Digital outputs	8	Line type	Resolution	Note
		PNP	Modbus cycle time	Max 500mA for each output. max 4A totally.
Current input of SHUNT	1	High side	0 – 3 A	Current read

2.3 Electromagnetic compatibility

The electromagnetic compatibility tests have been carried out at accredited laboratories, according to EN 61326-1, EN 61131-2 and EN 61000-6-2 standards .



Attention

Install the devices in electrical switchboards where temperature doesn't exceed 55 °C.

3 Product architecture

MPNE1001 is a device consisting of a base with some digital inputs and outputs and RTU modbus interface towards a master.

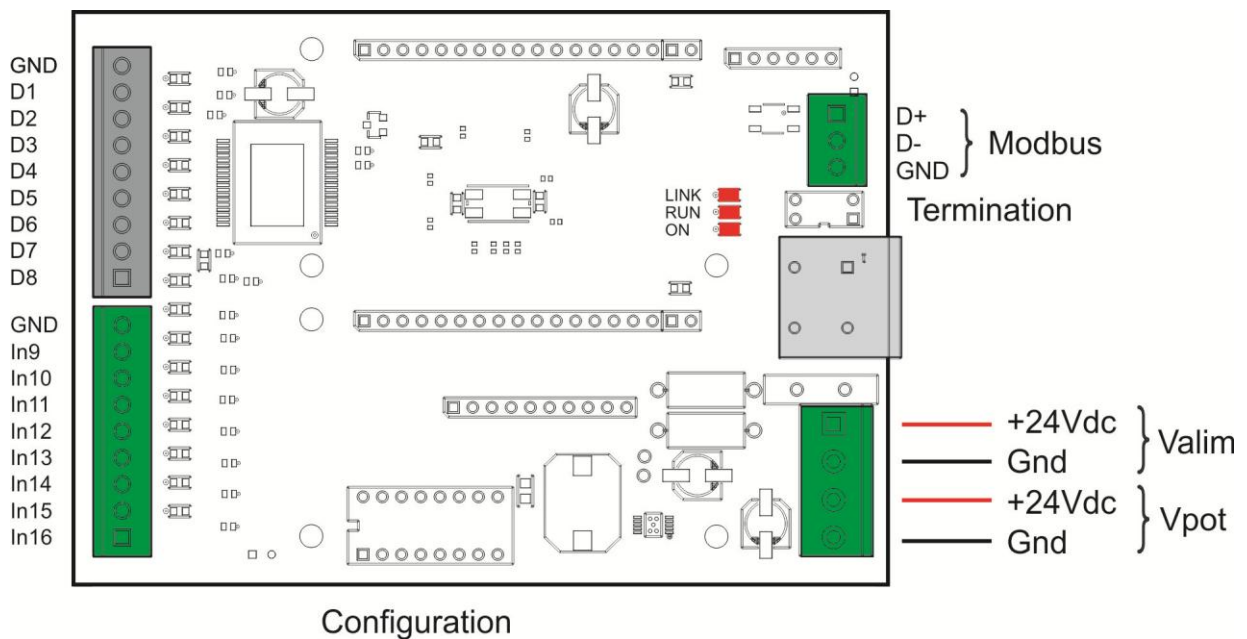

To the basic board, which includes 8 digital PNP inputs plus 8 digital PNP lines configurable as inputs or outputs, two expansion modules can be added at choice between:

1) 8 digital PNP inputs module – CODE 01

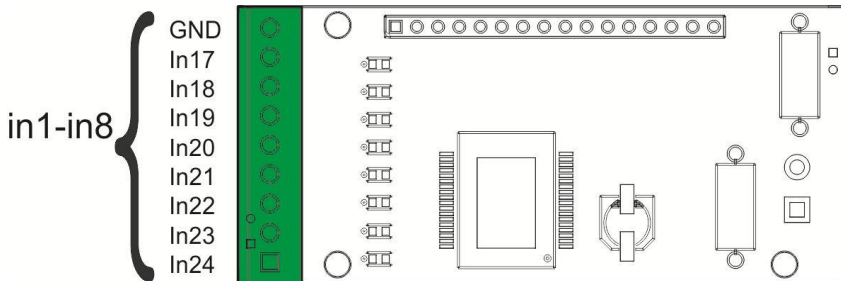

ATTENTION: It would be advisable that these inputs were not at a high logic level before the MPNE is completely ON because the inputs 23 and 31 of the expansions also have configuration functionality. **Wiring suggestion:** you could dissect the sensor / contact output in order to delay its activation or make sure that the output at the start of the system is always at a low logic level.

2) 8 digital PNP outputs module – CODE 02

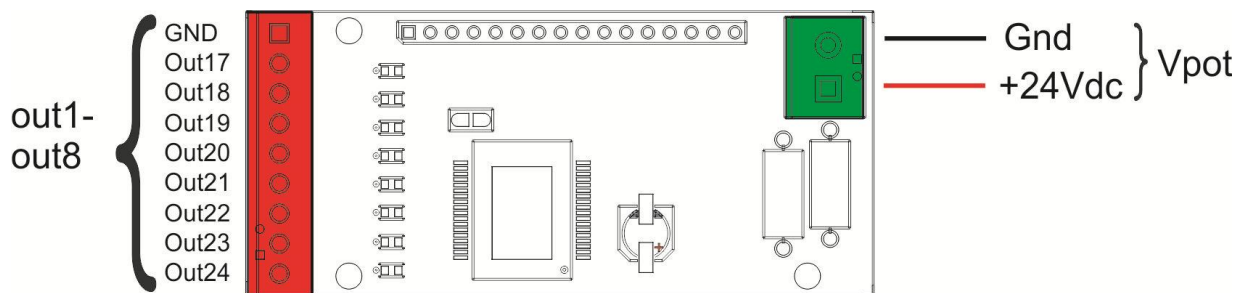

3) 2 universal analog inputs and 1 analog output module – CODE 05

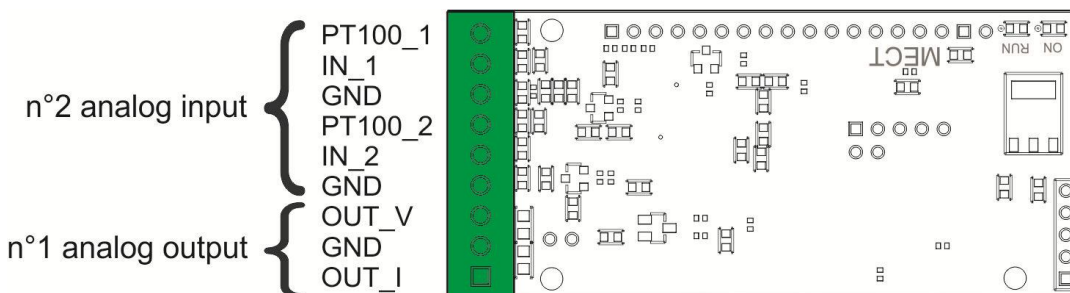

4) 8 digital PNP outputs and 1 current input 3A module – CODE 06

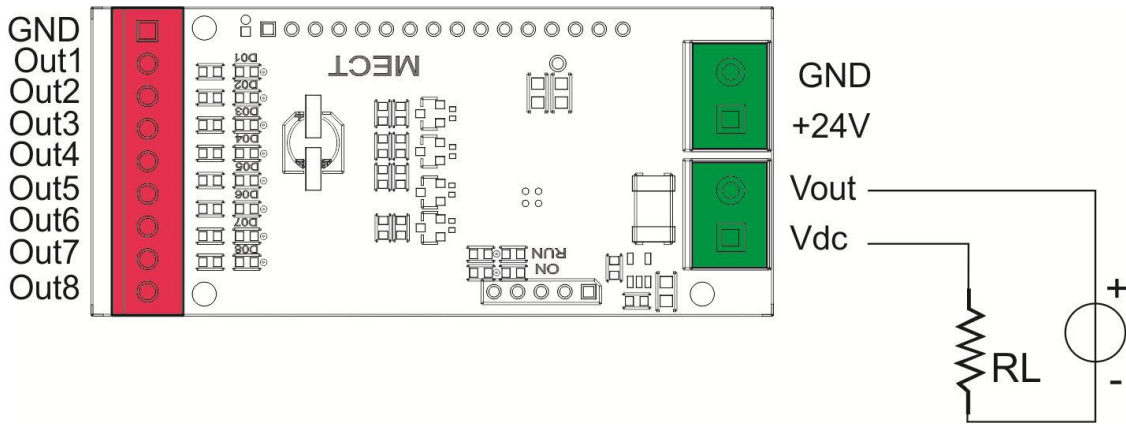

3.1 Models

Given the available modules, the models that can be realised are the following:

	Base	Expansion 1 (optional)	Expansion 2 (optional)	Format	Power supply	
MPNE10 BASE Version	01	00	00	SG	24	8 fixed digital inputs + 8 configurable digital I/O
		01 02 05 06				01: 8 digital inputs 02: 8 digital outputs 05: 2 analog inputs + 1 analog output 06: 8 digital outputs + 1 current shunt input (PRELIMINARY)
			01 02 05 06			01: 8 digital inputs 02: 8 digital outputs 05: 2 analog inputs + 1 analog output 06: 8 digital outputs + 1 current shunt input (PRELIMINARY)
				SG		Open frame
					24	24Vdc power supply

3.2 Installation

3.2.1 Distances

The system must be installed in a way that there is enough space for heat dissipation and cabling. Avoid cables superimposition to prevent EMC problems.

3.3 MPNE1001 Wiring

3.3.1 Isolation

On MPNE1001 there is not galvanic isolation between the main power supply and the internal communication bus.

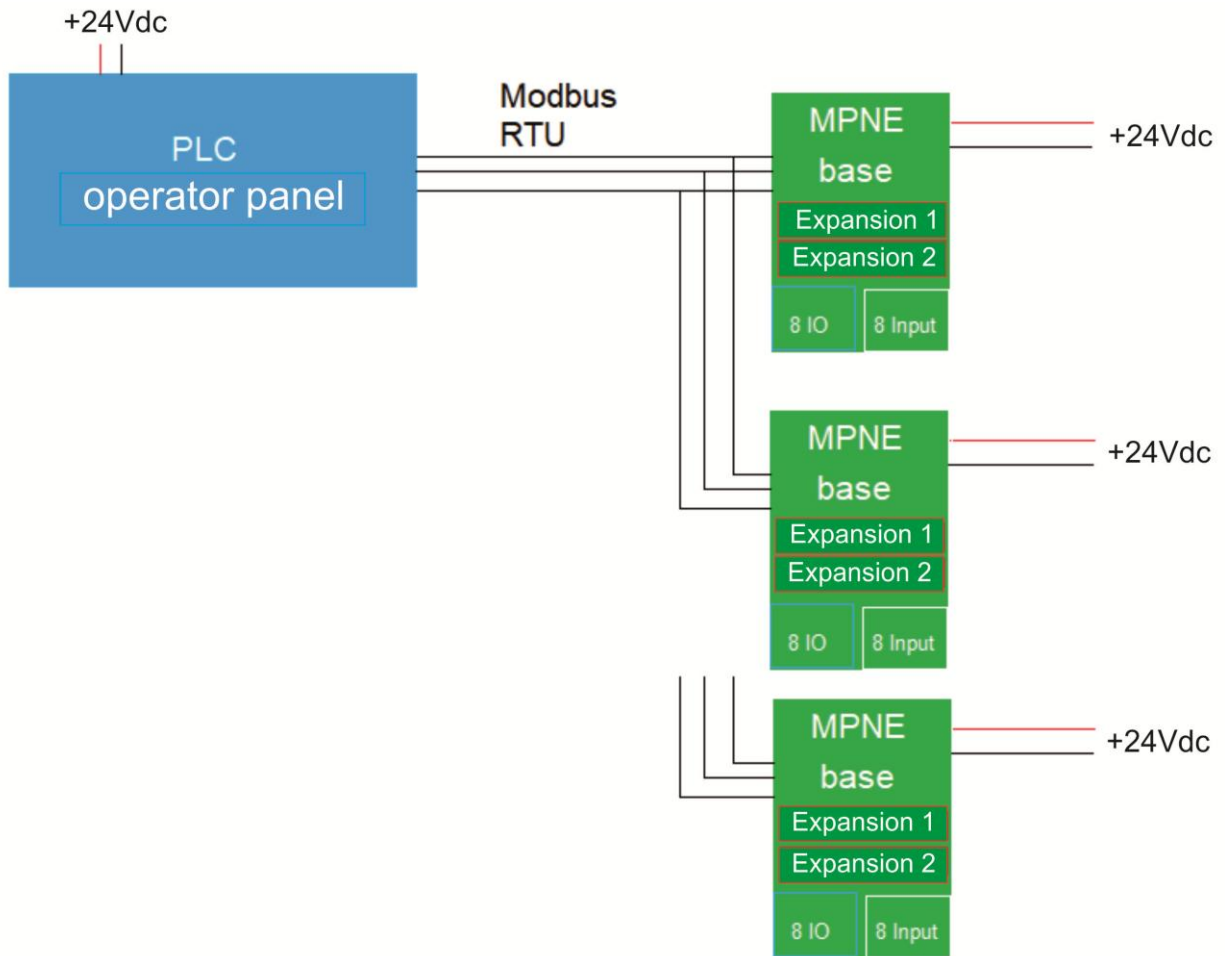
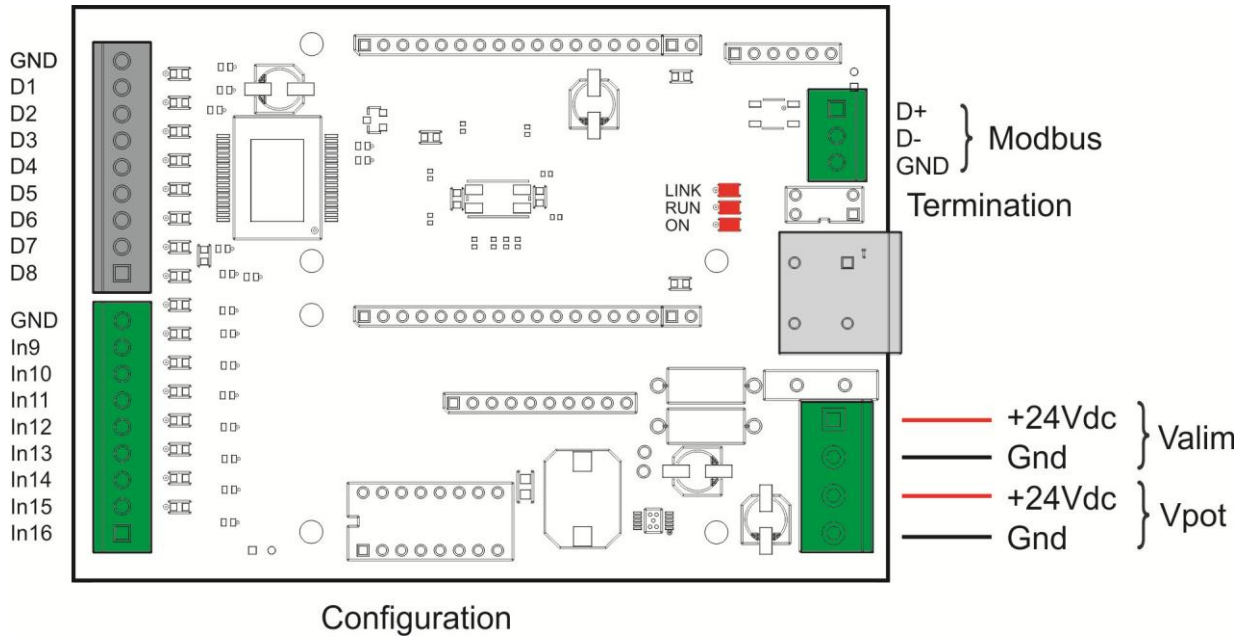

Fig.: logic chain

3.3.2 System power supply

The MPNE1001 requires a 24VDC (+/-15%) power supply as shown in the figure. The system is protected from the power supply polarity inversion.



Before turning on the device configure the Modbus setting, see chapter: [Modbus parameters configurations.](#)



Attention

Wrong value for the power supply can cause a irreversible damage to the device.

3.3.3 Digital outputs power supply

The digital outputs of the MPNE1001 are powered separately (**24Vpot**) from the circuit electronics so that they can be cut off from the emergency chain without disconnecting the low power part. The digital outputs can provide up to 2A maximum current at 24V (for CODE 02) and up to 4A maximum current at 24V (for CODE 06). The maximum allowable current per single output is 200mA (for CODE 02) and 500mA (for CODE 06). The current supplied by the outputs is supplied by the power supply of the terminal itself: it is the responsibility of the installer to correctly size the power supply to guarantee the necessary current.

In the figure below the power supply of digital outputs, of the base and of the expansions are shown:

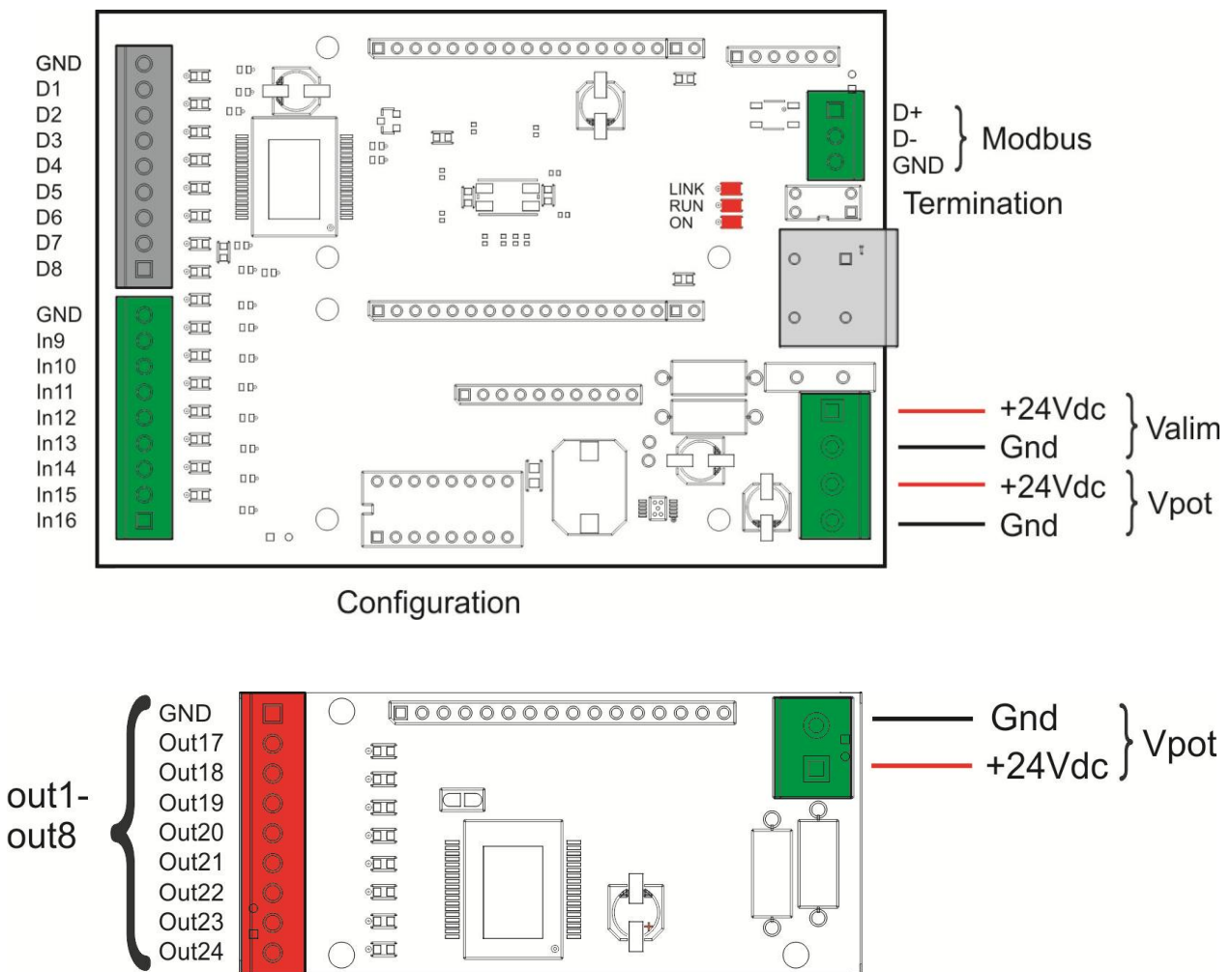

Fig.: Digital output connection

3.3.4 Fuses

The system has no fuses internally; however, for the protection of the input of the MPNE1001 power supply, it is recommended to insert a 1A fuse, while for the power it is necessary to put a 4A.

3.3.5 Grounding

The DIN rail on which are mounted the MPNE1001 and the terminals must be carefully grounded in order to increase the rejection of electromagnetic disturbances.

3.3.6 Cable screen

To make the system less sensible to disturbances, the connection cable between the operator panel and the MPNE1001 should be screened and connected to both devices GND.

3.4 I/O Connection

3.4.1 Base connection

The MPNE1001 can be used either alone or connected at the most to two expansions.

On MPNE1001 are available:

- 8 PNP digital Inputs –Outputs configurable via software;
- 8 PNP digital Inputs.

The figure below shows the terminal blocks for the connections of the digital inputs/outputs on the MPNE1001 base.

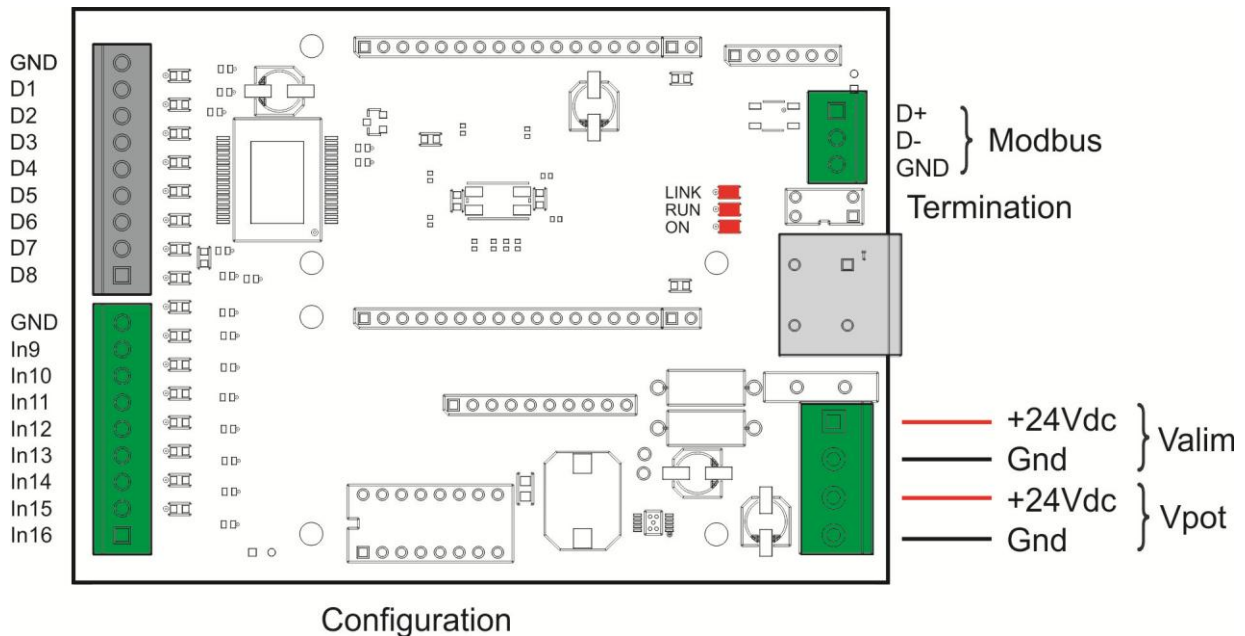
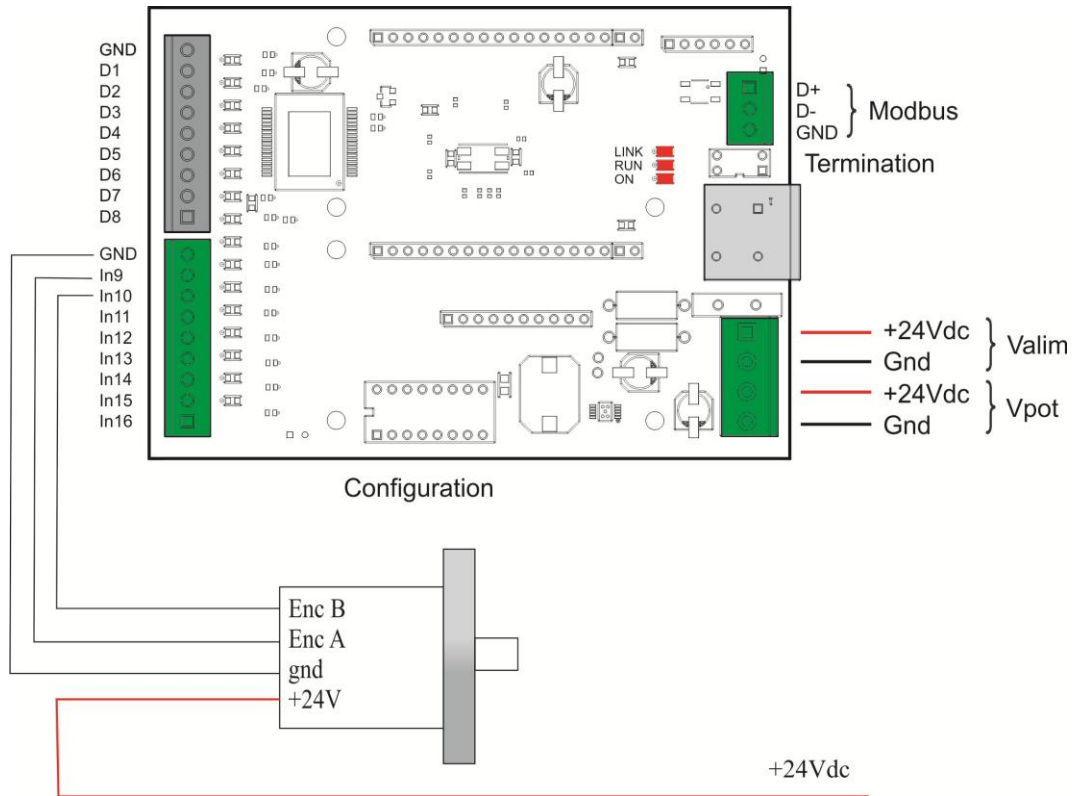

Fig.: Base connection

3.4.1.1 Base connection - encoder Bidirectional encoder



Unidirectional encoder

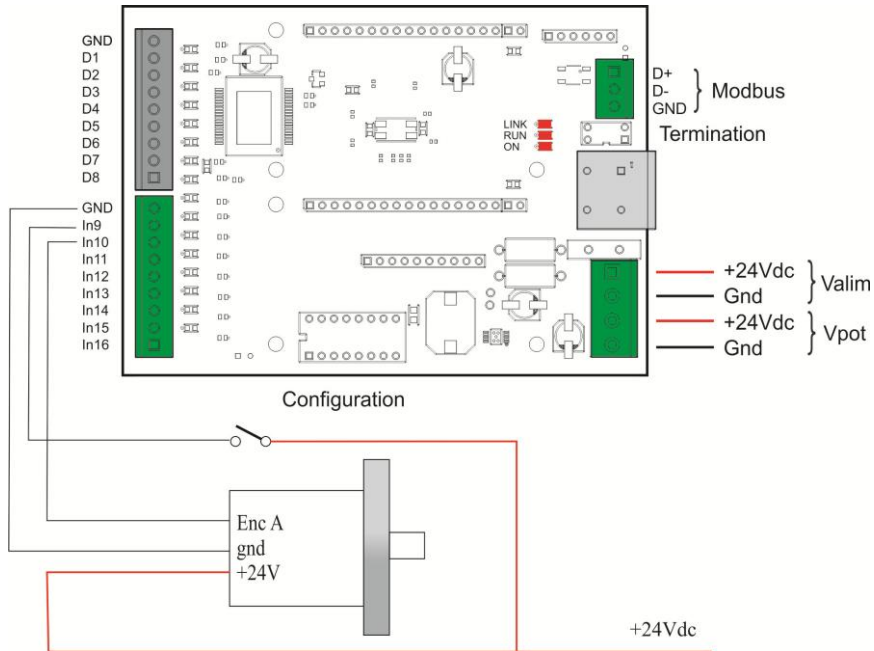

Fig.: Unidirectional encoder connection

Connect to the input “In10” count (Clock) while in the input “In9” the direction:

- In9 = 0 counter UP
- In9 = 1 (24V) counter down

3.4.2 Base + expansion digital inputs connection

On each base there can be at most two expansions in combination between digital inputs, digital and analog outputs. As far as the digital inputs are concerned, the pinout is as follows:

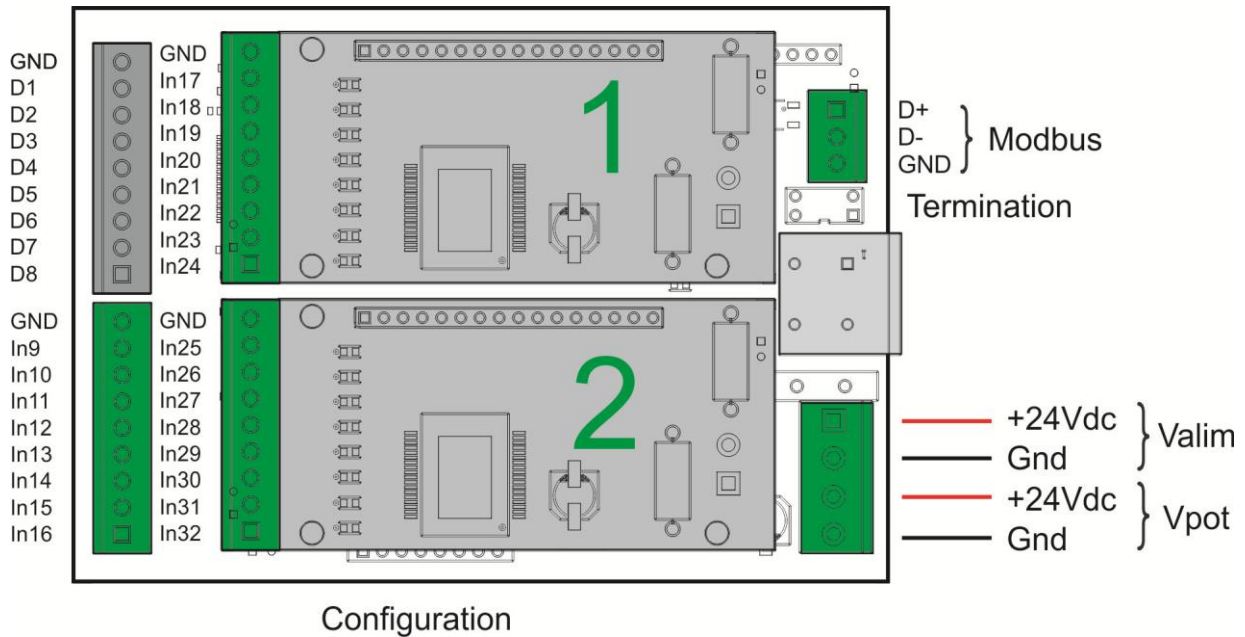

Fig.: Connection of the base + digital inputs (Expansion boards)

ATTENTION: It would be advisable that these inputs were not at a high logic level before the MPNE is completely ON because the inputs 23 and 31 of the expansions also have configuration functionality. **Wiring suggestion:** you could dissect the sensor / contact output in order to delay its activation or make sure that the output at the start of the system is always at a low logic level.

3.4.3 Digital inputs connection

If configured as inputs, the digital lines are PNP type.

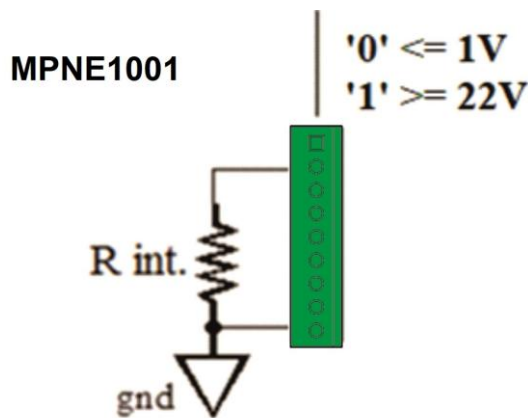

Fig.: Digital inputs

3.4.4 Base + expansion digital outputs connection

On each base there can be at most two expansions in combination between digital inputs, digital and analog outputs. If the expansions are of digital type, you obtain the following pinout:

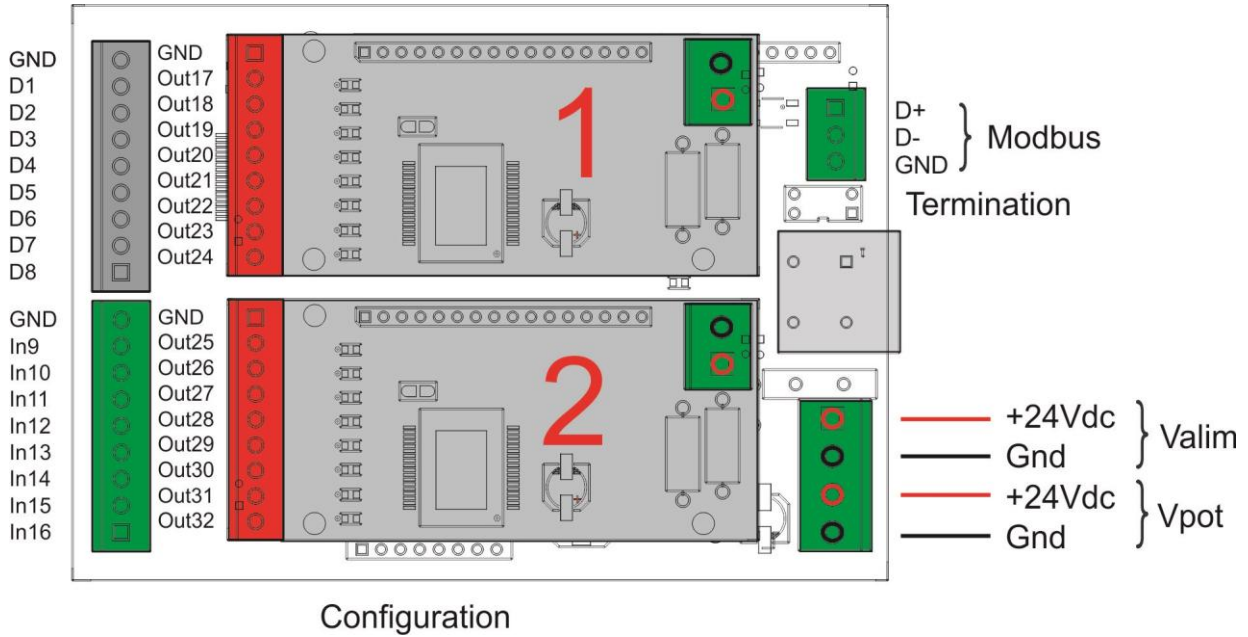

Fig.: Connection of the base + digital outputs (Expansion boards)

The lines on expansion board 1 are from 17 to 24, the lines on expansion board 2, from 25 to 32.

3.4.5 Digital outputs connection

If configured as outputs, the digital lines are PNP type.

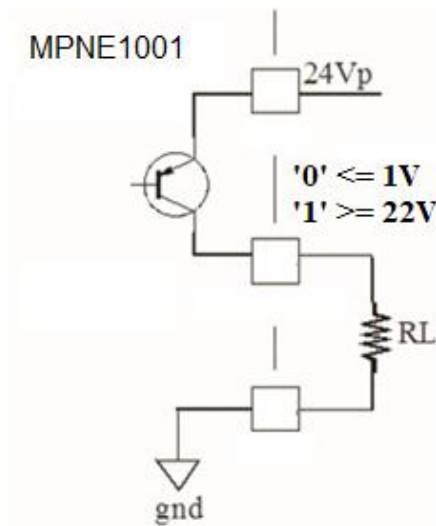

Fig.: Digital outputs

ATTENTION: each expansion should be supplied with 24V_{DC}.

3.4.6 Base + expansion analogue inputs / outputs connection

On each base there can be at most two expansions in combination between digital inputs, digital and analog outputs. If the expansions are of analog type , you obtain the following pinout:

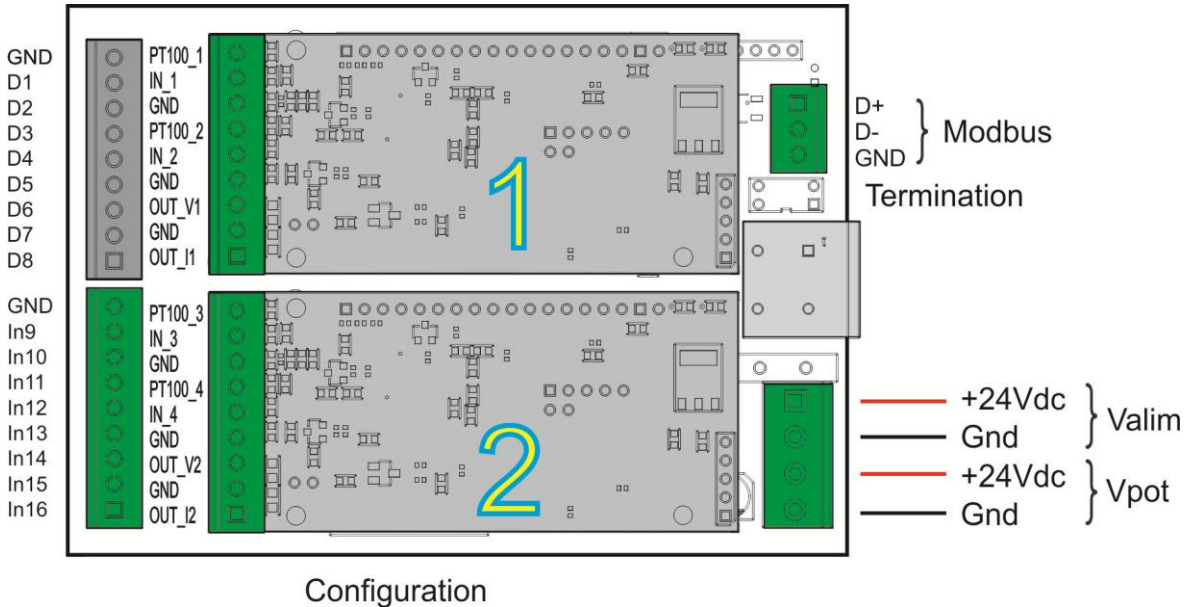
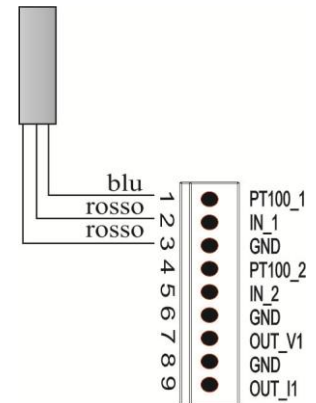

Fig.: Connection of the base + analog inputs / output (Expansion boards)

3.4.7 Analog inputs / output connection

3 wire PT100 input. Wiring with too high resistance can cause measure errors. To use 2 wire PT100 short terminals 2 and 3.



T/C input. Thermocouples must be isolated type. Use only proper thermocouples wire.

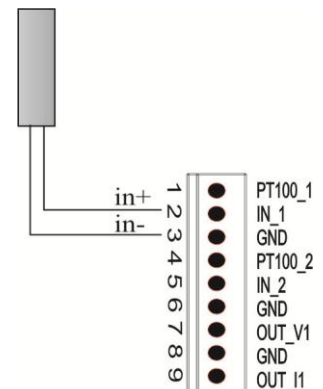

mA/V Input. Analogue inputs 4÷20mA and 0÷10V are connected to input and GND terminals. See figure to connect a 2 wire transducer with external power supply.

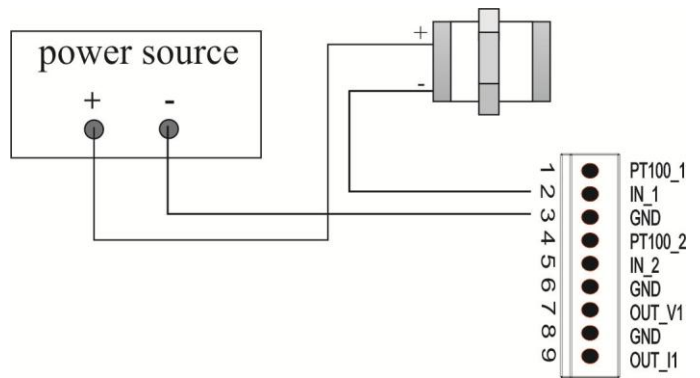

mA/V Output. Analog output 4÷20mA or 0÷10V is connected to output and GND terminals.

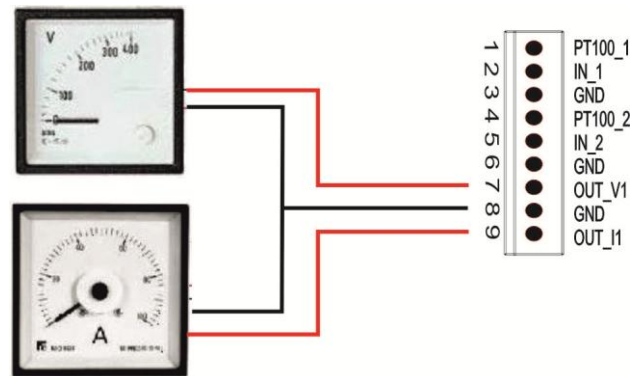

3.4.8 3A current input connection (PRELIMINARY)

Module 06 has the ability to measure the current delivered on a load up to 3A, the connection is of high side type as defined in the figure.

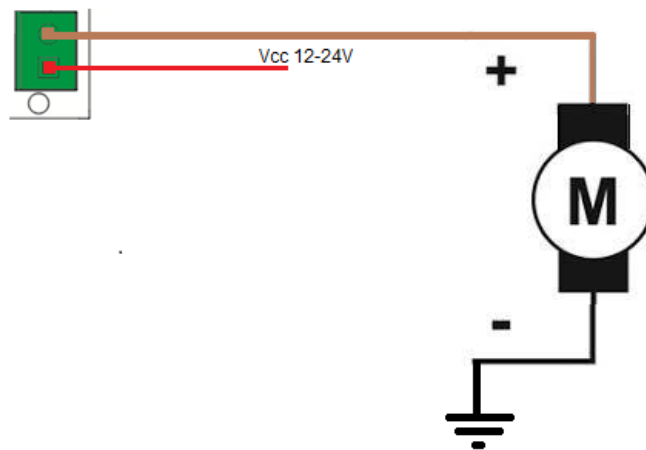

4 Modbus

4.1 Modbus parameters configurations

The 8th position dip-switch is used to change the baud rate, the address on the MPNE1001 and the stop and parity bit.



Fig.: Modbus parameters configuration

4.1.1 Address (ID module)

The address is set using switches **3** to **8**, so the valid addresses are 1 to 63.



It is important that the address setting is carried out before the MPNE1001 is turned on because one of the first operations carried out at the turn-on is the reading of the DIP status and if it detects that the address is zero it signals the error condition: the LED LINK flash.

The address is coded according to the following table:

S-3	S-4	S-5	S-6	S-7	S-8	ID node
0	0	0	0	0	0	Input in configuration
0	0	0	0	0	1	1
0	0	0	0	1	0	2
0	0	0	0	1	1	3
0	0	0	1	0	0	4
						...
1	1	1	1	1	0	62
1	1	1	1	1	1	63

To set 1 on the DIP switch, the switch must be set to the ON side.

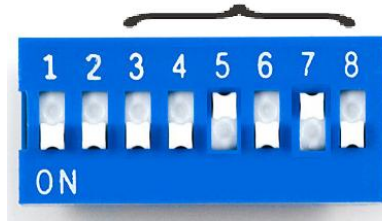

Fig.: Node address settings (ID)

Turn the device off and on again to make the changes effective.

4.1.2 Baud Rate settings

On the MPNE1001 you can set 4 different baud rates. The baud rate is set via the DIP switch 1 to 2. The permitted baud rate values are shown in the following table.

Switch settings		Baudrate
S-1	S-2	
0	0	9600
0	1	19200
1	0	38400
1	1	57600

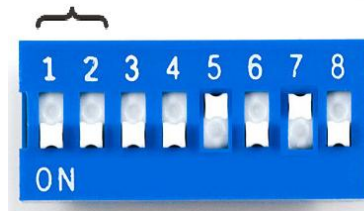

Fig.:Baud rate settings

Turn the device off and on again to make the changes effective.

4.1.3 Parity and stop bit configuration

If at the start the address dips ([ID module](#)) are all zero, the procedure for reading/setting the configuration of the stop and parity bits is accessed. The selection of the configuration type is made by reading dips 1 and 2.

Switch settings		Configuration
S-1	S-2	
0	0	Restore factory parameters
0	1	Parity bit
1	0	Stop bit

In this condition the LED LINK flashes.

Parity bit: S1=0; S2=1

Procedure:

- Set all dip switches to 0 except dip 2;
- Power up the instrument;
- Wait a few seconds until the LED LINK flashes;
- Carry out the desired **programming** (see below);
- Set dip 2 to 0 and wait for the LED RUN to light up;
- Switch off the instrument;
- Set the Baud rate and the desired address;
- Power up the instrument.

The parity **programming** is done by setting:

Dip settings		configuration
S-7	S-8	
0	1	No parity
1	1	Even parity
1	0	Odd parity

To save the configured value, bits S1 and S2 must be set to OFF.

As long as dips 3 to 8 are at 0, the LED RUN and LINK indicate the current parity configuration according to the following table, shown as below for the first 5 seconds.

Configuration	LED	
	RUN	LINK
No parity	OFF	ON
Even parity	ON	OFF
Odd parity	ON	ON

Stop bit: S1=1; S2=0

Procedure:

- Set all dip switches to 0 except dip 1;
- Power up the instrument;
- Wait a few seconds until the LED LINK flashes;
- Carry out the desired **programming** (see below);
- Set dip 1 to 0 and wait for the LED RUN to light up;
- Switch off the instrument;

- Set the Baud rate and the desired address;
- Power up the instrument.

The stop **programming** is done by setting:

Dip settings		Configuration
S-7	S-8	
0	1	1 stop bit
1	0	2 stop bit

To save the configured value, bits S1 and S2 must be set to OFF.

As long as dips 3 to 8 are at 0, the leds LED RUN e LINK indicate the current stop configuration according to the following table, shown as below for the first 5 seconds.

Configuration	LED	
	RUN	LINK
1 stop bit	OFF	ON
2 stop bit	ON	OFF

ATTENTION: It is not possible to set the "data bit" differently from the 8 bits as the Modbus RTU protocol requires data in this format.

4.1.4 Factory configuration

If at the start all the dips are at 0, it is possible to restore the configuration to the default values, and leds LED RUN and LINK are flashing until the bits from S3 to S8 are brought to 1.

This causes the device to be configured as:

- Stop bit: 1
- No parity

To activate the default configuration it is necessary to turn ON all bits from S3 to S8. This configuration is working if LED RUN is ON.

4.2 ModBus connection

The ModBus interface on the MPNE1001 is a 2-wire(plus gnd) RS485 serial port, built on removable terminals.

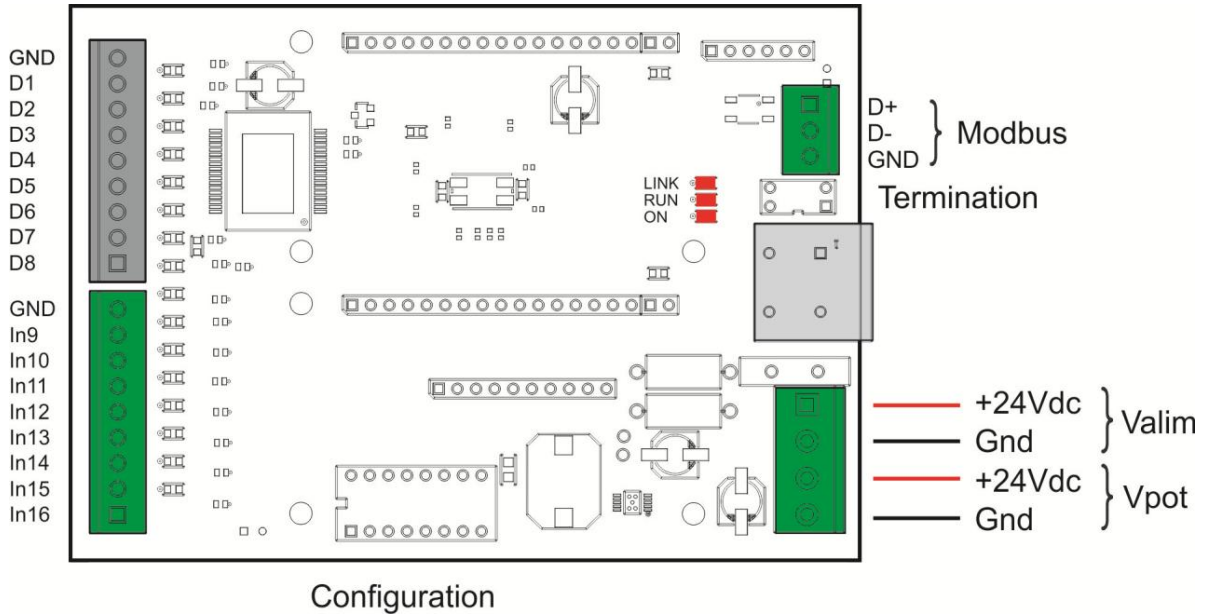

Fig.: ModBus Serial port

4.2.1 Installation example TPAC1007 / TP1043

This section describes an example for the commissioning of a system composed of:

- MPNE1001
- Master Modbus (TPAC1007 / TP1043)

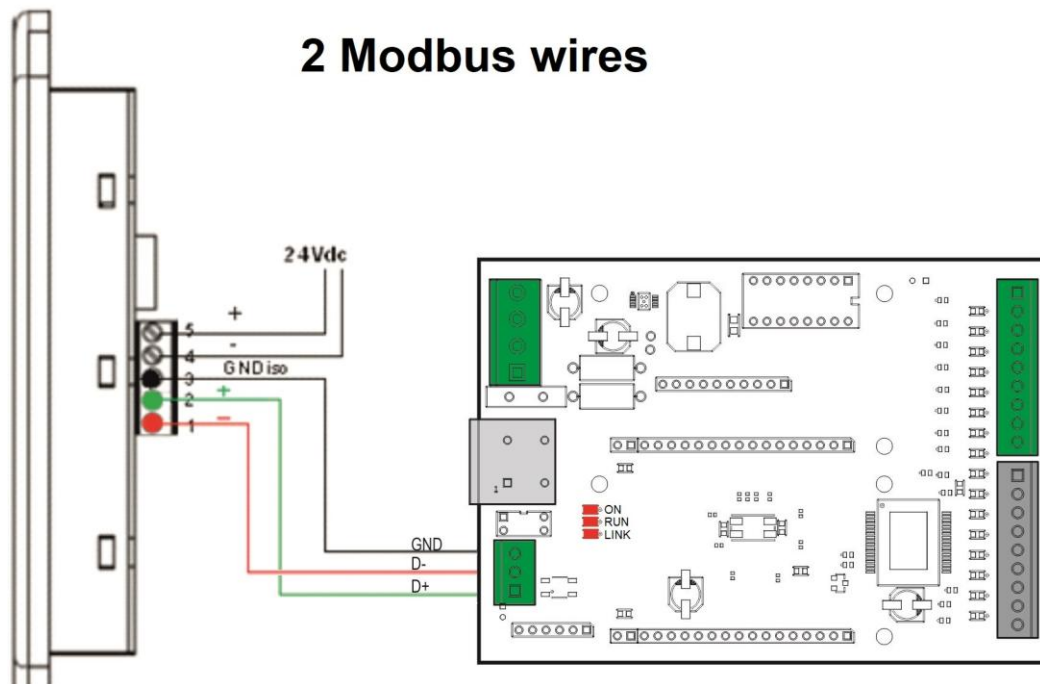

Fig.: Modbus connection

4.2.2 Installation example TPAC1008 / TP1070

This section describes an example for the commissioning of a system composed of:

- MPNE1001
- Master Modbus (TPAC1008 / TP1070)

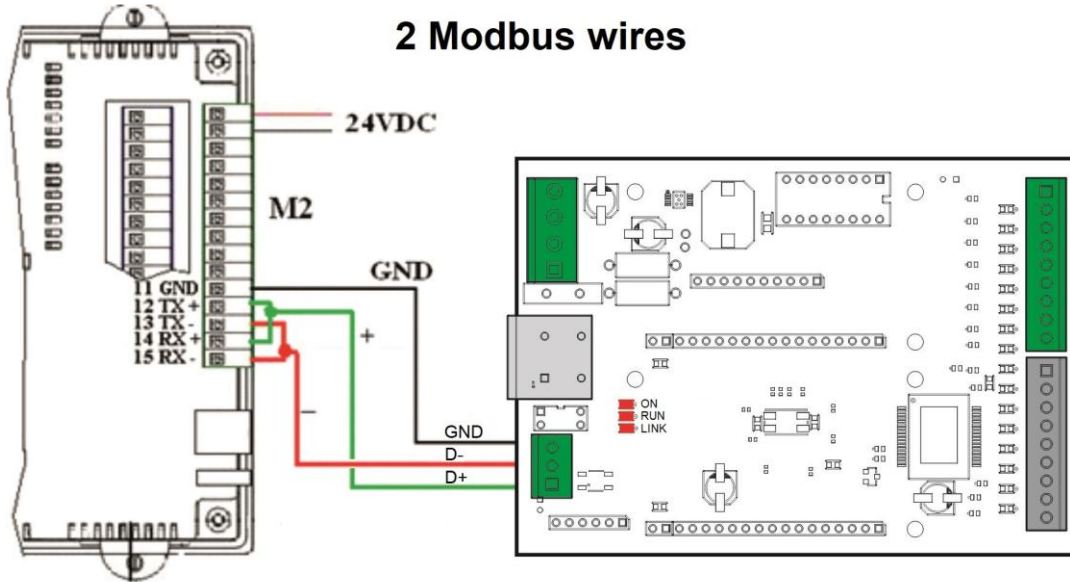

Fig.: Modbus connection

4.2.3 Terminating resistance

The two-position dip switch on the top of the unit inserts a 120 Ohm resistor on the RS485 line. Put both mini-dips to ON. Enter termination resistance only to the last device in the Modbus chain.



Fig.: Terminating resistance

4.3 Watchdog

MPNE1001 implements a watchdog function that resets the connected digital outputs if no query is received within the time set in the variable MPNE_Watchdog (expressed in seconds). To disable the watchdog function (default), simply set the variable to zero.

Once the watchdog is triggered on MPNE1001 the digital outputs are reset to zero and the LED LINK on the base is turned on .

5 Memory map ModBus RTU registers

The MPNE1001 is a RTU ModBus bridge. The following table shows the memory map.

ATTENTION: within the Crosstable Editor it is possible to import directly the variables associated to the registers. Press the right button inside the table and select “Paste MPNE10 Module”.

Variable	Type	Decimals	Modbus register	Access	Description
MPNE_FwRev	UINT	0	0	[RO]	Firmware revision
MPNE_ExpID	UINT	0	1	[RO]	Expansions identification
MPNE_ExpType	UINT	0	2	[RO]	Type of connected expansions Bit 0..3 expansion 1 present Bit 4..7 type of expansion 1 0 : no expansion 1: digital input expansion 2: digital outputs expansion 5: analog I/O Bit 8..11 expansion 2 present Bit 12..15 type of expansion 2
MPNE_SN	UDINT	0	3	[RO]	Serial number of BASE BOARD
MPNE_LifeTime	UDINT	0	5	[RO]	Lifetime 1s power on time MPNE
MPNE_Status	UINT	0	7	[RO]	MPNE communication status register 0: Idle 2: Run 3: watchdog
MPNE_DigIn_1	WORD_BIT	1	8	[RO]	Value of digital input 1
MPNE_DigIn_2	WORD_BIT	2	8	[RO]	Value of digital input 2
MPNE_DigIn_3	WORD_BIT	3	8	[RO]	Value of digital input 3
MPNE_DigIn_4	WORD_BIT	4	8	[RO]	Value of digital input 4
MPNE_DigIn_5	WORD_BIT	5	8	[RO]	Value of digital input 5
MPNE_DigIn_6	WORD_BIT	6	8	[RO]	Value of digital input 6
MPNE_DigIn_7	WORD_BIT	7	8	[RO]	Value of digital input 7
MPNE_DigIn_8	WORD_BIT	8	8	[RO]	Value of digital input 8
MPNE_DigIn_9	WORD_BIT	9	8	[RO]	Value of digital input 9
MPNE_DigIn_10	WORD_BIT	10	8	[RO]	Value of digital input 10
MPNE_DigIn_11	WORD_BIT	11	8	[RO]	Value of digital input 11
MPNE_DigIn_12	WORD_BIT	12	8	[RO]	Value of digital input 12
MPNE_DigIn_13	WORD_BIT	13	8	[RO]	Value of digital input 13
MPNE_DigIn_14	WORD_BIT	14	8	[RO]	Value of digital input 14
MPNE_DigIn_15	WORD_BIT	15	8	[RO]	Value of digital input 15
MPNE_DigIn_16	WORD_BIT	16	8	[RO]	Value of digital input 16
MPNE_DigIn_17	WORD_BIT	1	9	[RO]	Value of digital input 17
MPNE_DigIn_18	WORD_BIT	2	9	[RO]	Value of digital input 18
MPNE_DigIn_19	WORD_BIT	3	9	[RO]	Value of digital input 19

MPNE_DigIn_20	WORD_BIT	4	9	[RO]	Value of digital input 20
MPNE_DigIn_21	WORD_BIT	5	9	[RO]	Value of digital input 21
MPNE_DigIn_22	WORD_BIT	6	9	[RO]	Value of digital input 22
MPNE_DigIn_23	WORD_BIT	7	9	[RO]	Value of digital input 23
MPNE_DigIn_24	WORD_BIT	8	9	[RO]	Value of digital input 24
MPNE_DigIn_25	WORD_BIT	9	9	[RO]	Value of digital input 25
MPNE_DigIn_26	WORD_BIT	10	9	[RO]	Value of digital input 26
MPNE_DigIn_27	WORD_BIT	11	9	[RO]	Value of digital input 27
MPNE_DigIn_28	WORD_BIT	12	9	[RO]	Value of digital input 28
MPNE_DigIn_29	WORD_BIT	13	9	[RO]	Value of digital input 29
MPNE_DigIn_30	WORD_BIT	14	9	[RO]	Value of digital input 30
MPNE_DigIn_31	WORD_BIT	15	9	[RO]	Value of digital input 31
MPNE_DigIn_32	WORD_BIT	16	9	[RO]	Value of digital input 32
MPNE_AnIn_1	INT	0	10	[RO]	Value of analog Input 1 - Expansion 1
MPNE_AnIn_2	INT	0	11	[RO]	Value of analog Input 2 - Expansion 1
MPNE_AnIn_3	INT	0	12	[RO]	Value of analog Input 1 - Expansion 2
MPNE_AnIn_4	INT	0	13	[RO]	Value of analog Input 1 - Expansion 2
MPNE_AnInStatus	INT	0	14	[RO]	Analog inputs: status register 4 bit each input 0: Ok 1: overflow 2: opened probe
MPNE_Reg_1	UINT	0	15	[RW]	Riserved
MPNE_Reg_2	UINT	0	16	[RW]	Riserved
MPNE_Reg_3	UINT	0	17	[RW]	Riserved
MPNE_Reg_4	UINT	0	18	[RW]	Riserved
MPNE_StatusWord	UINT	0	25	[RW]	Special functions status register lines A,B,C,D
MPNE_Watchdog	UINT	0	26	[RW]	Watchdog register
MPNE_DigDir_1	WORD_BIT	1	27	[RW]	Digital line direction 1 (input = 0 output = 1)
MPNE_DigDir_2	WORD_BIT	2	27	[RW]	Digital line direction 2 (input = 0 output = 1)
MPNE_DigDir_3	WORD_BIT	3	27	[RW]	Digital line direction 3 (input = 0 output = 1)
MPNE_DigDir_4	WORD_BIT	4	27	[RW]	Digital line direction 4 (input = 0 output = 1)
MPNE_DigDir_5	WORD_BIT	5	27	[RW]	Digital line direction 5 (input = 0 output = 1)
MPNE_DigDir_6	WORD_BIT	6	27	[RW]	Digital line direction 6 (input = 0 output = 1)
MPNE_DigDir_7	WORD_BIT	7	27	[RW]	Digital line direction 7 (input = 0 output = 1)
MPNE_DigDir_8	WORD_BIT	8	27	[RW]	Digital line direction 8 (input = 0 output = 1)
MPNE_DigOut_1	WORD_BIT	1	28	[RW]	Driving of digital output 1
MPNE_DigOut_2	WORD_BIT	2	28	[RW]	Driving of digital output 2
MPNE_DigOut_3	WORD_BIT	3	28	[RW]	Driving of digital output 3
MPNE_DigOut_4	WORD_BIT	4	28	[RW]	Driving of digital output 4

MPNE_DigOut_5	WORD_BIT	5	28	[RW]	Driving of digital output 5
MPNE_DigOut_6	WORD_BIT	6	28	[RW]	Driving of digital output 6
MPNE_DigOut_7	WORD_BIT	7	28	[RW]	Driving of digital output 7
MPNE_DigOut_8	WORD_BIT	8	28	[RW]	Driving of digital output 8
MPNE_DigOut_17	WORD_BIT	1	29	[RW]	Driving of digital output 17
MPNE_DigOut_18	WORD_BIT	2	29	[RW]	Driving of digital output 18
MPNE_DigOut_19	WORD_BIT	3	29	[RW]	Driving of digital output 19
MPNE_DigOut_20	WORD_BIT	4	29	[RW]	Driving of digital output 20
MPNE_DigOut_21	WORD_BIT	5	29	[RW]	Driving of digital output 21
MPNE_DigOut_22	WORD_BIT	6	29	[RW]	Driving of digital output 22
MPNE_DigOut_23	WORD_BIT	7	29	[RW]	Driving of digital output 23
MPNE_DigOut_24	WORD_BIT	8	29	[RW]	Driving of digital output 24
MPNE_DigOut_25	WORD_BIT	9	29	[RW]	Driving of digital output 25
MPNE_DigOut_26	WORD_BIT	10	29	[RW]	Driving of digital output 26
MPNE_DigOut_27	WORD_BIT	11	29	[RW]	Driving of digital output 27
MPNE_DigOut_28	WORD_BIT	12	29	[RW]	Driving of digital output 28
MPNE_DigOut_29	WORD_BIT	13	29	[RW]	Driving of digital output 29
MPNE_DigOut_30	WORD_BIT	14	29	[RW]	Driving of digital output 30
MPNE_DigOut_31	WORD_BIT	15	29	[RW]	Driving of digital output 31
MPNE_DigOut_32	WORD_BIT	16	29	[RW]	Driving of digital output 32
MPNE_ControlWord_A	UINT	0	30	[RW]	Special function line A control register (see paragraph special functions)
MPNE_FastInDelay_A	UINT	0	31	[RW]	Special function line A – Fast input delay
MPNE_FastOutDelay_A	UINT	0	32	[RW]	Special function line A – Fast output delay
MPNE_FastOutDuration_A	UINT	0	33	[RW]	Special function line A – Fast output duration
MPNE_EncCounter_A	DINT	0	34	[RW]	Special function line A - Encoder Counter
MPNE_MatchRegister_A	DINT	0	36	[RW]	Special function line A - Match Encoder register
MPNE_PTOTargetFreq_A	UINT	0	38	[RW]	Special function line A - PTO Frequency
MPNE_PTOSTeps_A	UDINT	0	39	[RW]	Special function line A - PTO Steps
MPNE_PTORampUp_A	UINT	0	41	[RW]	Special function line A - PTO [s] Acceleration
MPNE_PTORampDown_A	UINT	0	42	[RW]	Special function line A - Deceleration PTO [s]
MPNE_ControlWord_B	UINT	0	43	[RW]	Special function line B control register (see paragraph special functions)
MPNE_FastInDelay_B	UINT	0	44	[RW]	Special function line B – Fast input delay
MPNE_FastOutDelay_B	UINT	0	45	[RW]	Special function line B – Fast output delay
MPNE_FastOutDuration_B	UINT	0	46	[RW]	Special function line B – Fast output duration
MPNE_EncCounter_B	DINT	0	47	[RO]	Special function line B - Encoder Counter
MPNE_MatchRegister_B	DINT	0	49	[RW]	Special function line B -

					Match Encoder register
MPNE_PTOTargetFreq_B	UINT	0	51	[RW]	Special function line B - PTO Frequency
MPNE_PTOSTeps_B	UDINT	0	52	[RW]	Special function line B - PTO Steps
MPNE_ControlWord_B1	UINT	0	54	[RW]	Special function line B control register (see paragraph special functions)
MPNE_PTORampDown_B	UINT	0	55	[RW]	Special function line B - PTO [s] Deceleration
MPNE_ControlWord_C	UINT	0	56	[RW]	Special function line C control register (see paragraph special functions)
MPNE_FastInDelay_C	UINT	0	57	[RW]	Special function line C – Fast input delay
MPNE_FastOutDelay_C	UINT	0	58	[RW]	Special function line C – Fast output delay
MPNE_FastOutDuration_C	UINT	0	59	[RW]	Special function line C – Fast output duration
MPNE_EncCounter_C	DINT	0	60	[RW]	Special function line C - Encoder Counter
MPNE_MatchRegister_C	DINT	0	62	[RW]	Special function line C - Match Encoder register
MPNE_PTOTargetFreq_C	UINT	0	64	[RW]	Special function line C - PTO Frequency
MPNE_PTOSTeps_C	UDINT	0	65	[RW]	Special function line C - PTO Steps
MPNE_ControlWord_C1	UINT	0	67	[RW]	Special function line C control register (see paragraph special functions)
MPNE_PTORampDown_C	UINT	0	68	[RW]	Special function line C - PTO [s] Deceleration
MPNE_ControlWord_D	UINT	0	69	[RW]	Special function line D control register (see paragraph special functions)
MPNE_FastInDelay_D	UINT	0	70	[RW]	Special function line D – Fast input delay
MPNE_FastOutDelay_D	UINT	0	71	[RW]	Special function line D – Fast output delay
MPNE_FastOutDuration_D	UINT	0	72	[RW]	Special function line D - Fast output duration
MPNE_EncCounter_D	DINT	0	73	[RO]	Special function line D - Encoder Counter
MPNE_MatchRegister_D	UDINT	0	75	[RW]	Special function line D - Match Encoder register
MPNE_PTOTargetFreq_D	UINT	0	77	[RW]	Special function line D - PTO Frequency
MPNE_PTOSTeps_D	UDINT	0	78	[RW]	Special function line D - PTO Steps
MPNE_ControlWord_D1	UINT	0	80	[RW]	Special function line D control register (see paragraph special functions)
MPNE_PTORampDown_D	UINT	0	81	[RW]	Special function line D - PTO [s] Deceleration

MPNE_AnIn1Conf	UINT	0	84	[RO]	Analog input 1 configuration, expansion 1: <ul style="list-style-type: none"> • 0 = not configured • 1 = current • 2 = voltage • 3 = TCJ (J type thermocouple) • 4 = TCK (K type thermocouple) • 5 = TCT (T type thermocouple) • 6 = PT100E (1 digit Resolution) range: -40 +800°C • 7 = PT100R (0.1 digit Resolution) range: -40 +200°C • 8 = TCS (S type thermocouple) • 9 = TCB (B type thermocouple) • 10 = TCR (R type thermocouple)
MPNE_AnIn2Conf	UINT	0	85	[RW]	Analog input 2 configuration, expansion 1: <ul style="list-style-type: none"> • 0 = not configured • 1 = current • 2 = voltage • 3 = TCJ (J type thermocouple) • 4 = TCK (K type thermocouple) • 5 = TCT (T type thermocouple) • 6 = PT100E (1 digit Resolution) range: -40 +800°C • 7 = PT100R (0.1 digit Resolution) range: -40 +200°C • 8 = TCS (S type thermocouple) • 9 = TCB (B type thermocouple) • 10 = TCR (R type thermocouple)
MPNE_AnIn3Conf	UINT	0	86	[RW]	Analog input 1 configuration, expansion 2: <ul style="list-style-type: none"> • 0 = not configured • 1 = current • 2 = voltage • 3 = TCJ (J type thermocouple) • 4 = TCK (K type thermocouple) • 5 = TCT (T type thermocouple) • 6 = PT100E (1 digit Resolution) range: -40 +800°C • 7 = PT100R (0.1 digit Resolution) range: -40 +200°C • 8 = TCS (S type thermocouple) • 9 = TCB (B type thermocouple) • 10 = TCR (R type thermocouple)
MPNE_AnIn4Conf	UINT	0	87	[RW]	Analog input 2 configuration, expansion 2: <ul style="list-style-type: none"> • 0 = not configured • 1 = current • 2 = voltage • 3 = TCJ (J type thermocouple) • 4 = TCK (K type thermocouple) • 5 = TCT (T type thermocouple) • 6 = PT100E (1 digit Resolution) range: -40 +800°C • 7 = PT100R (0.1 digit Resolution) range: -40 +200°C • 8 = TCS (S type thermocouple) • 9 = TCB (B type thermocouple)

					<ul style="list-style-type: none"> • 10 = TCR (R type thermocouple)
MPNE_AnOut1Conf	UINT	0	88	[RW]	Analog output 1 configuration - expansion 1: <ul style="list-style-type: none"> • 0 = not configured • 1 = current • 2 = voltage
MPNE_AnOut2Conf	UINT	0	89	[RW]	Analog output 1 configuration - expansion 2: <ul style="list-style-type: none"> • 0 = not configured • 1 = current • 2 = voltage
MPNE_AnOut1	UINT	0	90	[RW]	Analog output value - expansion 1
MPNE_AnOut2	UINT	0	91	[RW]	Analog output value - expansion 2
MPNE_AnIn1Filter	UINT	0	92	[RW]	Analog input 1 filter – expansion 1
MPNE_AnIn2Filter	UINT	0	93	[RW]	Analog input 2 filter – expansion 1
MPNE_AnIn3Filter	UINT	0	94	[RW]	Analog input 1 filter – expansion 2
MPNE_AnIn4Filter	UINT	0	95	[RW]	Analog input 2 filter – expansion 2
MPNE_ExpDigitalOut Config17_24	UINT	0	110	[RW]	Configuring digital outputs module 06 (two bits per channel) 00: Standard output (default) 01: monostable 10: PWM with duty cycle at 50% (only for outputs 22, 23 and 24) 11: PWM with duty cycle from 0% to 100% (only for outputs 22, 23 and 24)
MPNE_ExpPulseWidth1_ms	UINT	0	111	[RW]	Pulse duration (ms) for outputs configured as monostable
MPNE_Frequency_PWM1	UINT	0	112	[RW]	PWM output rate for channels defined as PWM
MPNE_PWM_OUT22_OUT21_DC	UINT	0	113	[RW]	Duty Cycle for configured channels such as PWM Bit 0..7 not used Bit 8..15 –HEX Duty Cycle – output 22
MPNE_PWM_OUT24_OUT23_DC	UINT	0	114	[RW]	Duty Cycle for configured channels such as PWM Bit 0..7 –HEX Duty Cycle – output 23 Bit 8..15–HEX Duty Cycle – output 24
MPNE_ShuntExp1	UINT	0	115	[RO]	Value in A x100. Current measured in module 06 slot 1
MPNE_ExpDigitalOut Config25_32	UINT	0	116	[RW]	Configuring digital outputs module 06 (two bits per channel) 00: Standard output (default) 01: monostable 10: PWM with duty cycle at 50%

					(only for outputs 30, 31 and 32) 11: PWM with duty cycle from 0% to 100% (only for outputs 30, 31 and 32)
MPNE_ExpPulseWidth2_ms	UINT	0	117	[RW]	Pulse duration (ms) for outputs configured as monostable
MPNE_Frequency_PWM2	UINT	0	118	[RW]	PWM output rate for channels defined as PWM
MPNE_PWM_OUT30_OUT29_DC	UINT	0	119	[RW]	Duty Cycle for configured channels such as PWM Bit 0..7 not used Bit 8..15 –HEX Duty Cycle – output 30
MPNE_PWM_OUT32_OUT31_DC	UINT	0	120	[RW]	Duty Cycle for configured channels such as PWM Bit 0..7 –HEX Duty Cycle – output 31 Bit 8..15–HEX Duty Cycle – output 32
MPNE_ShuntExp2	UINT	0	121	[RO]	Value in A x100. Current measured in module 06 slot 2
MPNE_Mir_LifeTimems	UDINT	0	400	[RO]	MPNE lifetime 1ms
MPNE_Mir_Status	UINT	0	402	[RO]	Mirror Reg.7-status register
MPNE_Mir_DigitalIn1	UINT	0	403	[RO]	Mirror Reg.8 - Digital input - Word1 In 1-16
MPNE_Mir_DigitalIn2	UINT	0	404	[RO]	Mirror Reg.9 - Digital input - Word2 In 17-32
MPNE_Mir_StatusWord	UINT	0	405	[RO]	Mirror Reg.25 - Fast Input Output
MPNE_Mir_EncCounter_A	DINT	0	406	[RO]	Mirror Reg.34 - Encoder Counter Line A
MPNE_Mir_ShuntExp1	INT	0	408	[RO]	Reserved
MPNE_Mir_ShuntExp2	INT	0	409	[RO]	Reserved
MPNE_Mir_Anin1	INT	0	410	[RO]	Mirror Reg.10 - Analog input 1 value
MPNE_Mir_Anin2	INT	0	411	[RO]	Mirror Reg.11 - Analog input 2 value
MPNE_Mir_Anin3	INT	0	412	[RO]	Mirror Reg.12 - Analog input 3 value
MPNE_Mir_Anin4	INT	0	413	[RO]	Mirror Reg.13 - Analog input 4 value
MPNE_Mir_AnInStatus	INT	0	414	[RO]	Mirror Reg.14 - Analog Inputs status register

5.1 Special functions

There are some I/O in the device that can be managed with a more advanced logic than the simple use as inputs and outputs. In particular, they are present:

- PTO outputs
- Encoder inputs
- Unidirectional counter inputs
- Fast inputs
- Fast outputs

Given these IOs, rapid response logics can be implemented without the explicit intervention of the PLC. From a logical point of view, there are four channels, but only some of them have all the functions.

Specific inputs and outputs are associated to each line, the association line with output inputs is described in the following table:

	LINE A resolution [μ s]	LINE B resolution [ms]	LINE C resolution [ms]	LINE D resolution [ms]
Fast Input	IN13	IN14	IN15	IN16
Fast Output	OUT 1	OUT 2	OUT 3	OUT 4
PTO	OUT 8	-	-	-
Encoder / counter	IN9 - IN10	IN14	IN15	IN16

5.1.1 Functions definition

The special lines can perform the following functions without the real-time intervention of the PLC, but by programming the appropriate registers. For each function listed, it is indicated which of the lines can perform it.

	Functionality	Description	Function-enabled channels
1	Output delayed with respect to the input	The output goes ON with a delay with respect to the arrival of the associated input. The output returns to zero when explicitly reconfigured by the PLC	<p>A min: 100µs max: 65ms Res.: 1µs Acc.: 20µs</p> <p>B,C,D min: 1ms max: 65s Res.: 1ms Acc.: 1ms</p>
2	Monostable output delayed with respect to the input	<p>The output goes ON with a delay with respect to the arrival of the associated input and remains ON for the set time</p> <p>For B, C and D lines, the exit is self-retriing. In practice, you don't need to rewrite the variable to trigger the event again.</p> <p>NOTE: If the input is not put OFF the output returns to ON after the set delay time.</p>	<p>A min: 100µs max: 65ms Res.: 1µs Acc.: 20µs</p> <p>B,C,D min: 1ms max: 65s Res.: 1ms Acc.: 1ms</p>
3	Monostable output	Following a command from the PLC, the output remains ON for the set time and then returns to OFF	<p>A min: 100µs max: 65ms</p>
4	Output at the end of the PTO	Output goes to ON at the end of the PTO count.	<p>A</p>

5	PTO start synchronized with the input	The PTO starts after the associated input 13 has been detected. If a delay is set on the input, the PTO starts at the end of the time	A
6	PTO start following a PLC command	The PTO starts after the PLC receives a start command	A
7	Output ON when matching value is reached on the encoder	OUT 1 goes ON when the count value reaches the value on the matching register. OUT 1 goes OFF after an encoder reset.	A
8	Encoder reset via fast input	Rising fast input (IN13) resets encoder value.	A

5.1.2 Variables

For each special line there is a group of variables that sets its operation

Variable Name	Type	Description	
MPNE_ControlWord_A	UINT	Variable for control of special functions. LINE: A	
		bit	
		0	PTO managed
		1	Fast In managed
		2	Fast OUT managed
		3	Encoder managed
		4	PTO Run on Fast Input
		5	Fast OUT on Fast Input
		6	Fast OUT on match register
		7	Fast OUT on PTO DONE
		8	Enable unidirectional Counter
		9	Enable reset encoder on Fast Input
		10	Reset Counter
		11	Update Encoder conf
12	Update Fast Input		
13	PTO Run		

		<table border="1"> <tr> <td data-bbox="772 152 852 203">14</td> <td data-bbox="852 152 1447 203">Update Fast OUT</td> </tr> <tr> <td data-bbox="772 203 852 696">15</td> <td data-bbox="852 203 1447 696"> 1 = Bit Set 0 = Bit Reset To set bit 0 (PTO managed) write: MPNE_ControlWord_A := 16#8001; To reset bit 2 (Fast OUT managed) write: MPNE_ControlWord_A := 16#0004; </td> </tr> </table>	14	Update Fast OUT	15	1 = Bit Set 0 = Bit Reset To set bit 0 (PTO managed) write: MPNE_ControlWord_A := 16#8001; To reset bit 2 (Fast OUT managed) write: MPNE_ControlWord_A := 16#0004;												
14	Update Fast OUT																	
15	1 = Bit Set 0 = Bit Reset To set bit 0 (PTO managed) write: MPNE_ControlWord_A := 16#8001; To reset bit 2 (Fast OUT managed) write: MPNE_ControlWord_A := 16#0004;																	
<p>MPNE_ControlWord_B MPNE_ControlWord_C MPNE_ControlWord_D</p>	<p>UINT</p>	<p>Variable for control of special functions. LINE: B, C, D</p> <table border="1"> <tr> <td data-bbox="772 831 852 882">bit</td> <td data-bbox="852 831 1447 882"></td> </tr> <tr> <td data-bbox="772 882 852 934">1</td> <td data-bbox="852 882 1447 934">Fast In managed</td> </tr> <tr> <td data-bbox="772 934 852 985">2</td> <td data-bbox="852 934 1447 985">Fast OUT managed</td> </tr> <tr> <td data-bbox="772 985 852 1037">5</td> <td data-bbox="852 985 1447 1037">Fast OUT on Fast Input</td> </tr> <tr> <td data-bbox="772 1037 852 1088">10</td> <td data-bbox="852 1037 1447 1088">Reset Counter</td> </tr> <tr> <td data-bbox="772 1088 852 1140">12</td> <td data-bbox="852 1088 1447 1140">Update Fast Input</td> </tr> <tr> <td data-bbox="772 1140 852 1191">14</td> <td data-bbox="852 1140 1447 1191">Update Fast OUT</td> </tr> <tr> <td data-bbox="772 1191 852 1771">15</td> <td data-bbox="852 1191 1447 1771"> 1 = Bit Set 0 = Bit Reset To set bit 1 (Fast In managed) write: MPNE_ControlWord_B := 16#8002; To reset bit 2 (Fast OUT managed) write: MPNE_ControlWord_B := 16#0004; To reset counter: MPNE_ControlWord_B := 16#8400; </td> </tr> </table>	bit		1	Fast In managed	2	Fast OUT managed	5	Fast OUT on Fast Input	10	Reset Counter	12	Update Fast Input	14	Update Fast OUT	15	1 = Bit Set 0 = Bit Reset To set bit 1 (Fast In managed) write: MPNE_ControlWord_B := 16#8002; To reset bit 2 (Fast OUT managed) write: MPNE_ControlWord_B := 16#0004; To reset counter: MPNE_ControlWord_B := 16#8400;
bit																		
1	Fast In managed																	
2	Fast OUT managed																	
5	Fast OUT on Fast Input																	
10	Reset Counter																	
12	Update Fast Input																	
14	Update Fast OUT																	
15	1 = Bit Set 0 = Bit Reset To set bit 1 (Fast In managed) write: MPNE_ControlWord_B := 16#8002; To reset bit 2 (Fast OUT managed) write: MPNE_ControlWord_B := 16#0004; To reset counter: MPNE_ControlWord_B := 16#8400;																	
<p>MPNE_ControlWord_B1 MPNE_ControlWord_C1 MPNE_ControlWord_D1</p>	<p>UINT</p>	<p>Variable for control of special functions. LINE: B, C, D</p> <table border="1"> <tr> <td data-bbox="772 1906 852 1957">bit</td> <td data-bbox="852 1906 1447 1957"></td> </tr> <tr> <td data-bbox="772 1957 852 2009">1</td> <td data-bbox="852 1957 1447 2009">Steady state OUT (High or Low)</td> </tr> </table> <p>If set to 1, the output is ON, and returns to</p>	bit		1	Steady state OUT (High or Low)												
bit																		
1	Steady state OUT (High or Low)																	

		OFF when the trigger condition intervenes. If set to 0 the output is OFF, and returns to ON when the trigger condition intervenes
MPNE_FastInDelay_x	UINT	Time value expressed in: <ul style="list-style-type: none"> • μs for LINE A • ms for LINE B,C,D
MPNE_FastOutDelay_x	UINT	Time value expressed in: <ul style="list-style-type: none"> • μs for LINE A • ms for LINE B,C,D
MPNE_FastOutDuration_x	UINT	Time value expressed in: <ul style="list-style-type: none"> • μs for LINE A • ms for LINE B,C,D
MPNE_EncCounter_x	DINT	Encoder counter
MPNE_MatchRegister_x	DINT	Number of counts reached when the associated output (if enabled) goes to ON and remains there until it is expressly reset by the PLC. The number as not to be 0.
MPNE_PTOTargetFreq_x	UINT	PTO Frequency expressed in Hz (max value 65kHz)
MPNE_PTO_Steps_x	UDINT	Number of steps that the PTO will emit
MPNE_PTO_RampUp_A	UINT	N.A.
MPNE_PTO_RampDown_x	UINT	N.A.
MPNE_StatusWord	UINT	Reading PTO status Variables , 4 bit for each line are assigned: 00 IDLE 01 STEPPING 10 DONE 11 ERROR The most significant bit of each line indicates whether the corresponding "Fast OUT" output has been enabled. LINE A: bit 3 LINE B: bit 7 LINE C: bit 11

		<p>LINE D: bit 15</p> <p>The bit will return to 0 if you disable the current configuration or re-arm the feature with an update.</p>
--	--	--

5.1.3 Management of IOs

The management of Fast IOs, PTOs and encoders is done by setting the ControlWord register (CW) and the bits are shown in the table. From the PLC point of view, the programmer can use free MECT-provided libraries, on demand, or make the following settings:

PTO Management

To manage the PTOs, the programmer must set the CW for the following function:

Bit																Description
15	14	13	12	11	10	9	8	7	6	5	4	3	2	1	0	
0	0	0	0	0	0	0	0	0	0	0	0	0	0	0	1	<p>PTO disabled.</p> <p>MPNE_ControlWord_A := 16#0001;</p>
1	0	1	0	0	0	0	0	0	0	0	0	0	0	0	1	<p>PTO Start from PLC.</p> <p>(Function 6)</p> <p>MPNE_ControlWord_A := 16#A001;</p> <p>Variables set:</p> <p>MPNE_PTOTargetFreq_A MPNE_PTO_Steps_A</p> <p>When parameters change, the function must be re-armed by rewriting the CW</p>
1	0	0	1	0	0	0	0	0	0	0	1	0	0	1	1	<p>PTO start following a rising edge on the associated input.</p> <p>(Function 5)</p> <p>MPNE_ControlWord_A := 16#9013;</p> <p>Variables set:</p> <p>MPNE_PTOTargetFreq_A MPNE_PTO_Steps_A MPNE_FastInDelay_A</p> <p>When parameters change, the function must be re-armed by rewriting the CW</p>

1	0	1	0	0	0	0	0	0	0	1	0	0	0	0	0	1	0	0	<p>Fast OUT 1 on PTO DONE (Function 4) MPNE_ControlWord_A := 16#A084; Variables set: MPNE_PTOTargetFreq_A MPNE_PTO_Steps_A When parameters change, the function must be re-armed by rewriting the CW</p>
---	---	---	---	---	---	---	---	---	---	---	---	---	---	---	---	---	---	---	---

Fast Output Management

To manage the fast I/Os, the programmer must set the CW for the following function:

Bit																		Description	
15	14	13	12	11	10	9	8	7	6	5	4	3	2	1	0				
0	1	0	0	0	0	0	0	0	0	0	0	0	0	1	0	0			<p>Fast OUT disabled. MPNE_ControlWord_A := 16#4004;</p>
1	1	0	1	0	0	0	0	0	0	0	1	0	0	1	1	0			<p>Output is active following an edge on Fast In. (Function 1 and 2) MPNE_ControlWord_A := 16#D026; Variables set: (Function 1 and 2) MPNE_FastOutDelay_X (Function 2) MPNE_FastOutDuration_X When parameters change, the function must be re-armed by rewriting the CW</p>
1	1	0	0	0	0	0	0	0	0	0	0	0	0	1	0	0			<p>You activate the output for a fixed time by a plc command. (Function 3) MPNE_ControlWord_A := 16#C004; Variables set: MPNE_FastOutDuration_A When parameters change, the function must be re-armed by rewriting the CW</p>

ENCODER Management

To manage the encoder, the programmer must set the CW for the following function:

Bit																Description
15	14	13	12	11	10	9	8	7	6	5	4	3	2	1	0	
0	0	0	0	1	0	0	0	0	0	0	0	1	0	0	0	<p>Disabled Encoder (paused reading): MPNE_ControlWord_A := 16#0808;</p>
1	0	0	0	1	0	0	1	0	0	0	0	1	0	0	0	<p>Unidirectional Counter: MPNE_ControlWord_A := 16#8908;</p>
1	0	0	0	1	0	0	0	0	0	0	0	1	0	0	0	<p>Bidirectional Encoder: MPNE_ControlWord_A := 16#8808;</p>
1	1	0	0	1	0	0	0	0	1	0	0	0	1	0	0	<p>The OUT 1 is activated when the encoder count value is reached with respect to the value set on the matching register. (Function 7) MPNE_ControlWord_A := 16#C844; Variables set: MPNE_MatchRegister_A Re-arm the function by rewriting the CW:</p> <ul style="list-style-type: none"> • To disable OUT 1 • Every parameters change
1	0	0	0	0	1	0	0	0	0	0	0	0	0	0	0	<p>Reset Counter MPNE_ControlWord_A := 16#8400;</p>
1	0	0	1	0	0	1	0	0	0	0	0	0	0	1	0	<p>Reset Counter via fast input (IN13). (Function 8) MPNE_ControlWord_A := 16#9202;</p>

UNIDIRECTIONAL COUNTERS Management LINES B, C, D

This feature is available from Firmware version 17

The unidirectional counters on inputs IN14, IN15, IN16, are always enabled and increment the associated count variable, on each rising edge detected on the line. The inputs also operate in parallel as normal digital inputs.

The maximum accepted frequency for rising edge detection on the lines is 500Hz.

To reset the counter associated with a line, simply set the controlWord to the value of 16#8400.

IN14: line B				
	Variable	Register	Type	Note
Counter	MPNE_EncCounter_B	47	DINT	
Reset	MPNE_ControlWord_B	43	UINT	16#8400

IN15: line C				
	Variable	Register	Type	Note
Counter	MPNE_EncCounter_C	60	DINT	
Reset	MPNE_ControlWord_C	56	UINT	16#8400

IN16: line D				
	Variable	Register	Type	Note
Counter	MPNE_EncCounter_D	73	DINT	
Reset	MPNE_ControlWord_D	69	UINT	16#8400

5.2 Module 06 Functions (*PRELIMINARY*)

Module 06 provides in some of its lines the possibility to implement special functions.

5.2.1 Monostable outputs

All 06 expansion module lines can be configured as monostable outputs.

Configuration is done through the registers:

MPNE_ExpDigitalOutConfig17_24

MPNE_ExpDigitalOutConfig25_32

Respectively for module 1 and 2.

The configuration consists of two bits for each line according to the following table:

MPNE_ExpDigitalOutConfig17_24					
		Standard output	Monostable output	PWM 50%	PWM 0% - 100%
Line 17	Bit 0	0	0	X	X
Line 17	Bit 1	0	1	X	X
Line 18	Bit 0	0	0	X	X
Line 18	Bit 1	0	1	X	X
Line 19	Bit 0	0	0	X	X
Line 19	Bit 1	0	1	X	X
Line 20	Bit 0	0	0	X	X
Line 20	Bit 1	0	1	X	X
Line 21	Bit 0	0	0	X	X
Line 21	Bit 1	0	1	X	X
Line 22	Bit 0	0	0	1	1
Line 22	Bit 1	0	1	0	1
Line 23	Bit 0	0	0	1	1
Line 23	Bit 1	0	1	0	1
Line 24	Bit 0	0	0	1	1
Line 24	Bit 1	0	1	0	1

MPNE_ExpDigitalOutConfig25_32					
		Standard output	Monostable output	PWM 50%	PWM 0% - 100%
Line 25	Bit 0	0	0	X	X
Line 25	Bit 1	0	1	X	X
Line 26	Bit 0	0	0	X	X
Line 26	Bit 1	0	1	X	X
Line 27	Bit 0	0	0	X	X
Line 27	Bit 1	0	1	X	X
Line 28	Bit 0	0	0	X	X
Line 28	Bit 1	0	1	X	X
Line 29	Bit 0	0	0	X	X
Line 29	Bit 1	0	1	X	X
Line 30	Bit 0	0	0	1	1
Line 30	Bit 1	0	1	0	1
Line 31	Bit 0	0	0	1	1
Line 31	Bit 1	0	1	0	1
Line 32	Bit 0	0	0	1	1
Line 32	Bit 1	0	1	0	1

As shown above, the lines that can be configured as PWM are only the last three for each module .

5.2.2 Using lines as monostable

The monostable lines are outputs , when commanded by a writing, they remain at an high level for the time indicated in the register **MPNE_ExpPulseWidth1_ms**, then come back to a low level.

To use module 1 lines as monostable outputs, you must set the **MPNE_ExpPulseWidth1_ms** register to configure the duration in milliseconds and configure the corresponding line with the register.

MPNE_ExpDigitalOutConfig17_24 as 01

To configure module 2, please refer to the registers: **MPNE_ExpPulseWidth2_ms** and **MPNE_ExpDigitalOutConfig25_32**.

All lines can be configured as monostable. Duration time is common to all lines in the module.

5.2.3 Using lines as PWM

Lines 22, 23, 24, 30, 31 and 32 can be configured as PWM. There are two possible PWM configurations, one with 50% duty-cycle and the other with a configurable duty-cycle between 0 and 100%.

To use lines such as PWM, you must configure the following registers:

- MPNE_ExpDigitalOutConfig17_24 / MPNE_ExpDigitalOutConfig25_32
- MPNE_Frequency_PWM1 / MPNE_Frequency_PWM2
- MPNE_PWM_OUT22_OUT21_DC / MPNE_PWM_OUT24_OUT23_DC / MPNE_PWM_OUT30_OUT29_DC / MPNE_PWM_OUT32_OUT31_DC

Once the registers are configured, bringing the corresponding line to 1, the outgoing signal is emitted.

For example, if you want to emit a 1kHz frequency signal with duty-cycle 10% on line 24, please follow the following instructions (ST code):

```
MPNE_ExpDigitalOutConfig17_24 := 16#C000; (* bits 14 and 15 configured as 11 *)
MPNE_PWM_OUT24_OUT23_DC := 16#0A00; (* high byte configured with 10 (10%) *)
MPNE_Frequency_PWM1 := 1000; (* frequency 1000 Hz *)
MPNE_DigOut_24 := true; (*output 24 activation *)
```

6 Status led

Under operating conditions, the status of the MPNE1001 is indicated by the LEDs on the device.

LED	Signification
LED On	Indicates the presence of the supply voltage
LED RUN	Blinks with each modbus transaction
LED LINK	Watchdog triggered
Digital LED	Digital IO Status Led

6.1 Led On

ON at power on. Indicates the presence of power supply on the circuit.

6.2 Led RUN

The run led has the task to signal the communication between MPNE1001 and the PLC; the led flashes with each transaction with modbus.

Flashing	Modbus Communication active
Fixed: switched off	Modbus Communication not active

6.3 Led LINK

The LED LINK lights up if the watchdog is triggered.

Moreover, during the start phase, the LEDs signal the configurations according to the DIP switch setting. See chapter "[Modbus parameters configuration](#)".

6.4 Digital I/O Led

On each digital line there is a signalling led that indicates if on the associated line there is a voltage of 24V.